

WEBTOON

Creative Guideline

Display Ads



Display Ads Mobile

- ✓ The asset can be placed on one or more of the below placements
- ✓ Various placements of Ads leaving a long-lasting impression of your brand

Premium Home Ad

Interactive Video

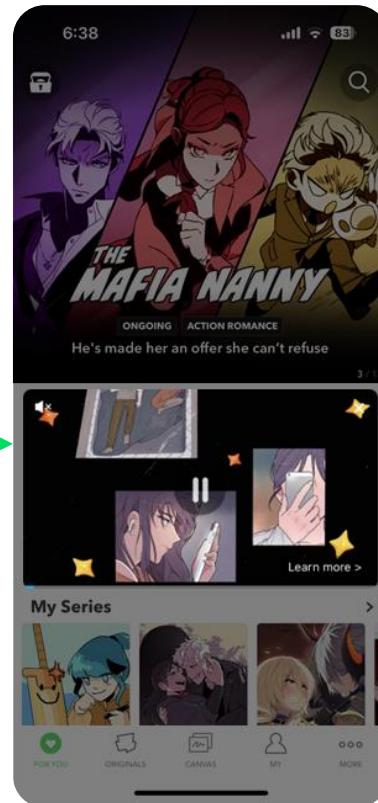
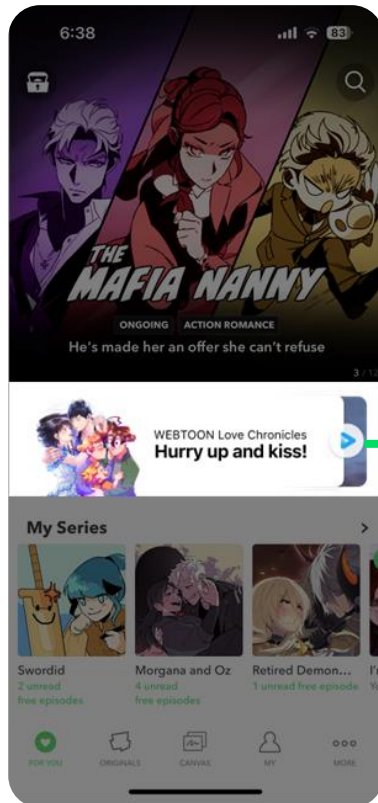

Native Image

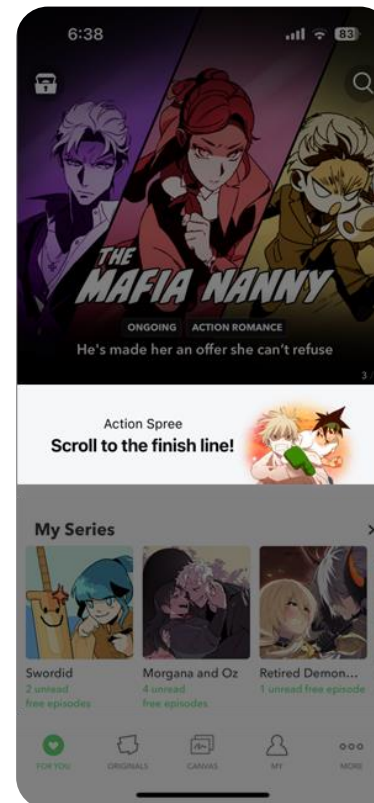

Banner Image

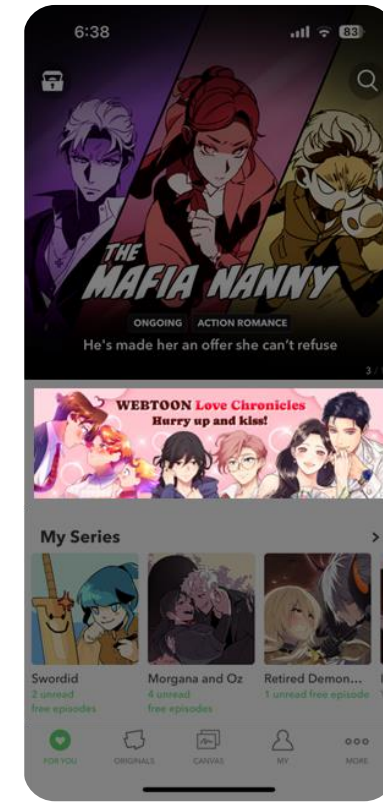

Display Ads Mobile

- ✓ The asset can be placed on one or more of the below placements
- ✓ Various placements of Ads leaving a long-lasting impression of your brand

In-Viewer

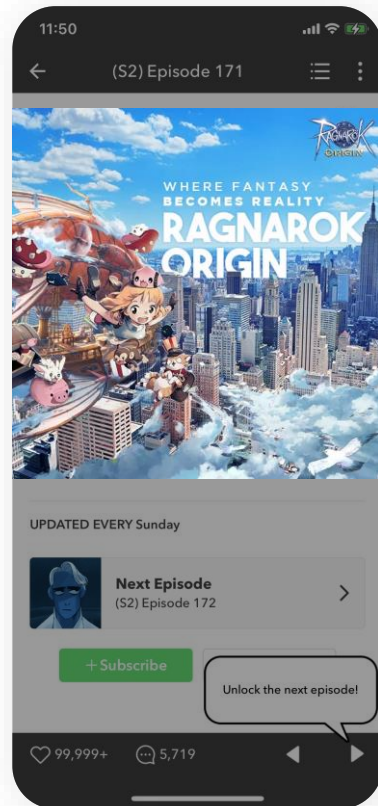

Series Home AD

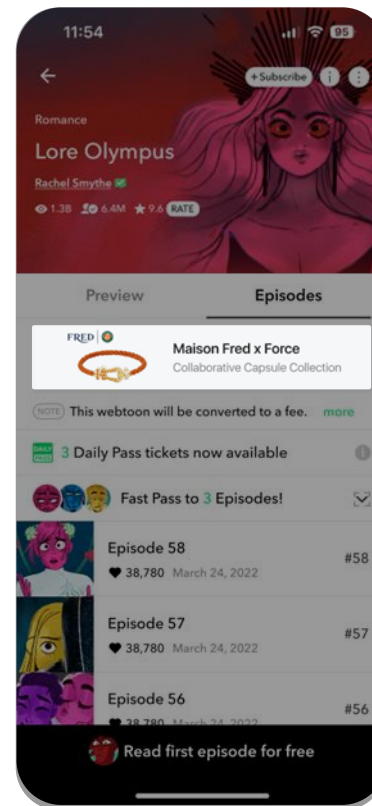

User Profile

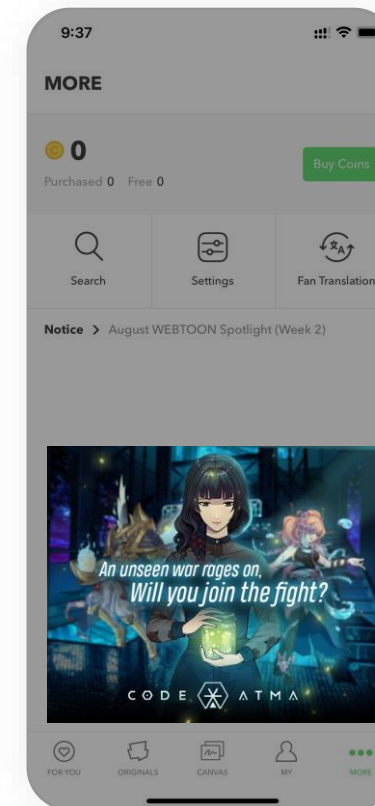

Display Ads Mobile

- ✓ The asset can be placed on one or more of the below placements
- ✓ Various placements of Ads leaving a long-lasting impression of your brand

1:1 Video

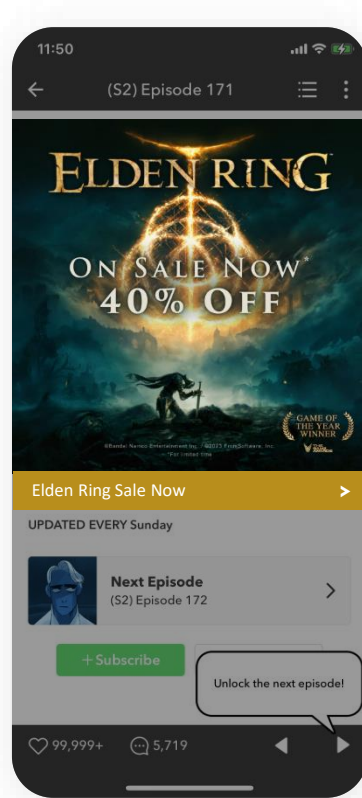

Full Screen Video (non skip 30 sec)

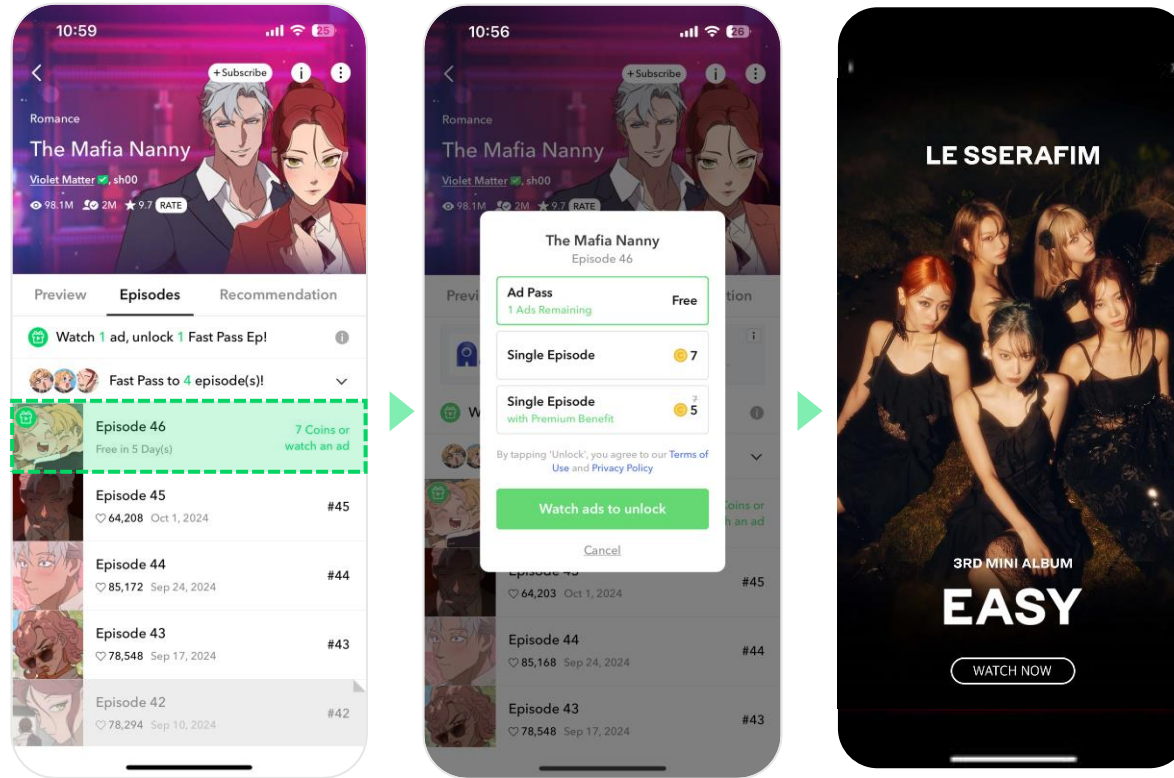

Premium Home AD _ Interactive Video

PSD File

Placement

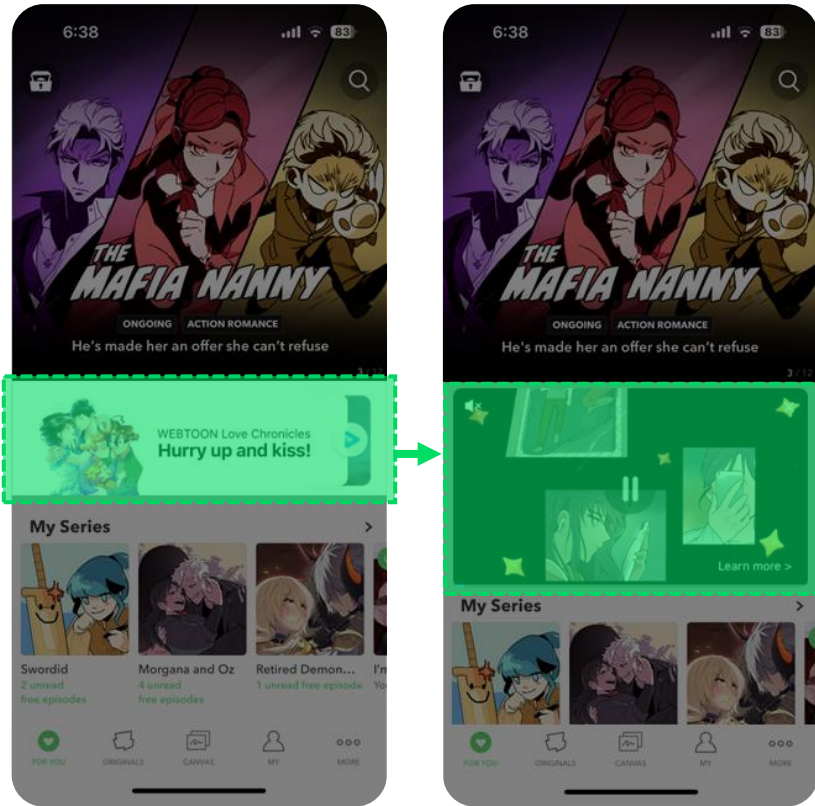

1 Premium Image



Expose the affordance

2 Video thumbnail image



When swipe the Premium Image, it expands into a video

3 16:9 Video



Play the video

4 Default image

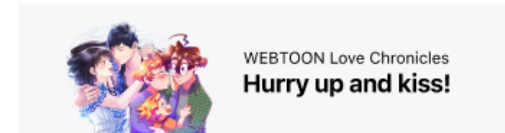

Expose the default image under poor network connection, which doesn't allow video play.

Premium Home AD _ Interactive Video

PSD File

1 Premium Image

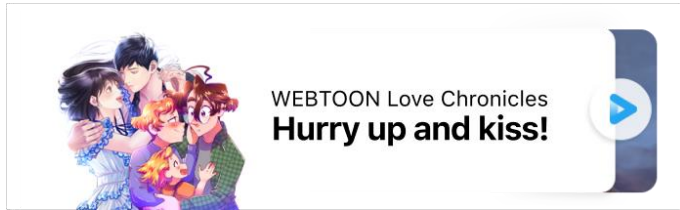

Object area

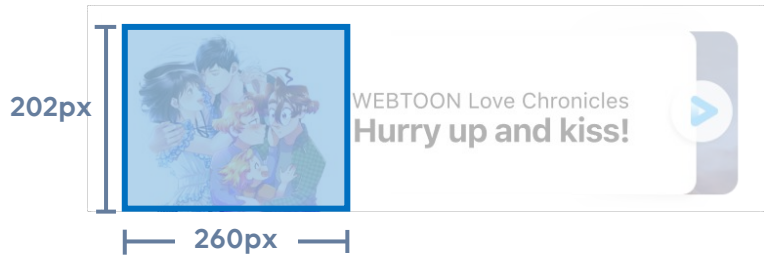

Text area

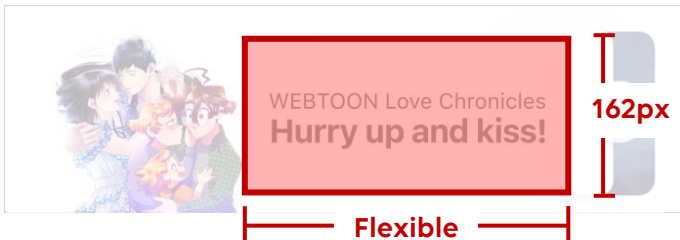

Length & Height (+ Margin)

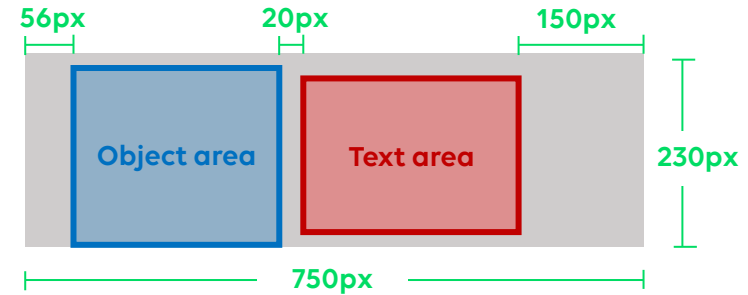

* For detailed guideline, refer to the sample mock-up provided through PSD.

Specifications

File type	File size limit	Length & Height
PNG	< 150KB	750 x 230

- * **Transparent Background image in PNG format only**
- * Each Object and Text should be placed within the specified area
- * Use visible and readable fonts for copy line
- * Brand logo, colored texts are also allowed for Text area
- * **Call-to-Action button is not allowed to insert**

Premium Home AD _ Interactive Video

BAD CASE for Premium Image (750x230)



Opaque background (affordance/video still cuts cannot be seen)



Object image area incompliant with the guide

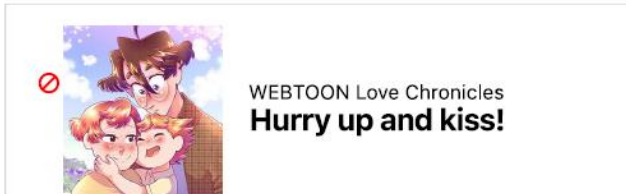

Object image with opaque background



Failure to use sample PSD for production of Text & Background type

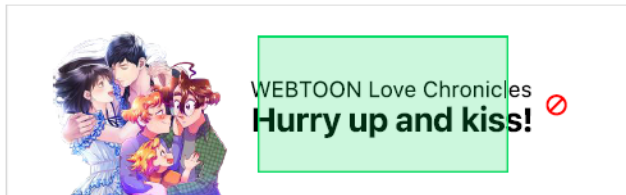

Text area incompliant with the guide (part of the text may be cropped)

Premium Home AD _ Interactive Video

2 Video thumbnail image



Length & Height

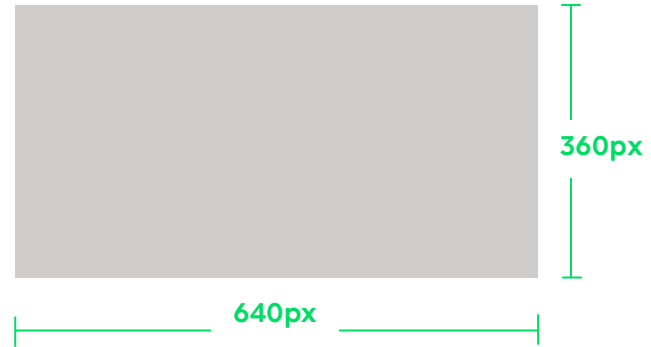

Specifications

File type	File size limit	Length & Height
JPG, PNG	< 150KB	640 x 360

Premium Home AD _ Interactive Video

3 16:9 Video

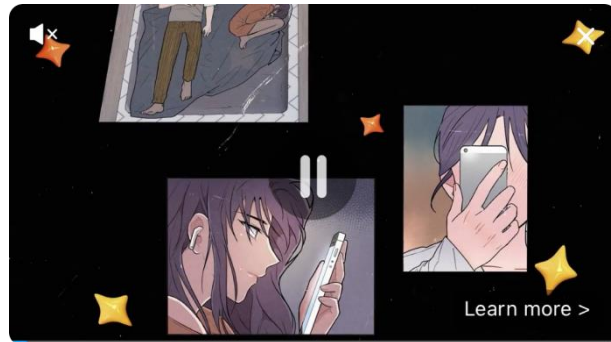

Length & Height



Specifications

File type	File size limit	Length & Height
MP4, AVI, WMV	< 1 Gb / Under 60s* <i>*Make sure not to exceed 60.00 sec</i>	1920 x 1080

* The video should be relevant to the ad message

** Sound must be included*

Premium Home AD _ Interactive Video

PSD File

4 Default image

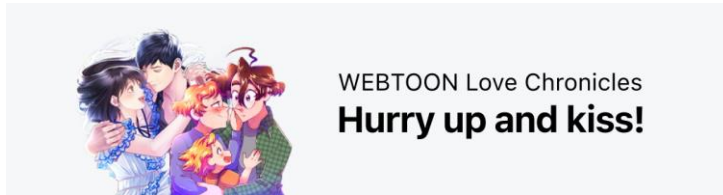

Default Image is exposed under poor network connection, which doesn't allow video play. Please align its tone and manner with Premium Image by following right-hand guidelines.

Length & Height (+ Margin)

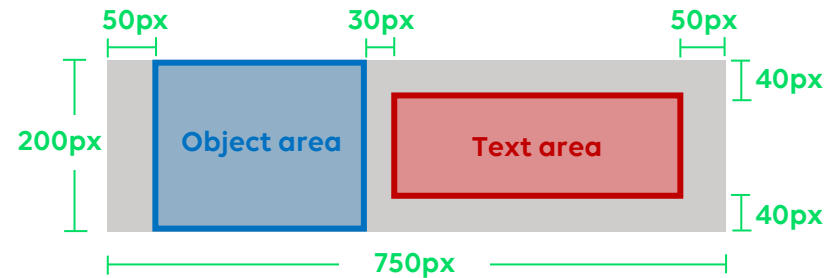

* For detailed guideline, refer to the sample mock-up provided through PSD.

Specifications

File type	File size limit	Length & Height
PNG	150KB	750 x 200

- * **Transparent Background image in PNG format only**
- * The object can be place either on the left-hand side or on the right-hand side
- * Use visible and readable fonts for copy line
- * Brand logo, colored texts are also allowed for Text area
- * **Call-to-Action button is not allowed to insert**

Premium Home AD _ Interactive Video

BAD CASE for Default Image (750x200)



Opaque background (affordance/video still cuts cannot be seen)



Object image area incompliant with the guide

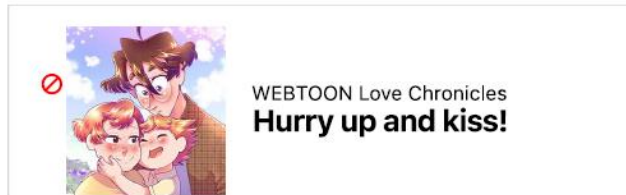

Object image with opaque background



Failure to use sample PSD for production of Text & Background type

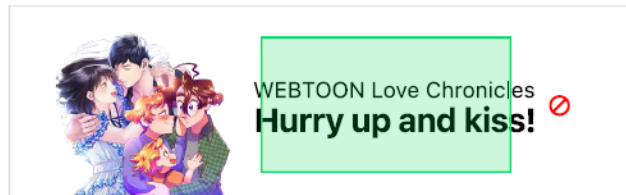

Text area incompliant with the guide (part of the text may be cropped)

Premium Home AD _ Native Image

PSD File

Placement

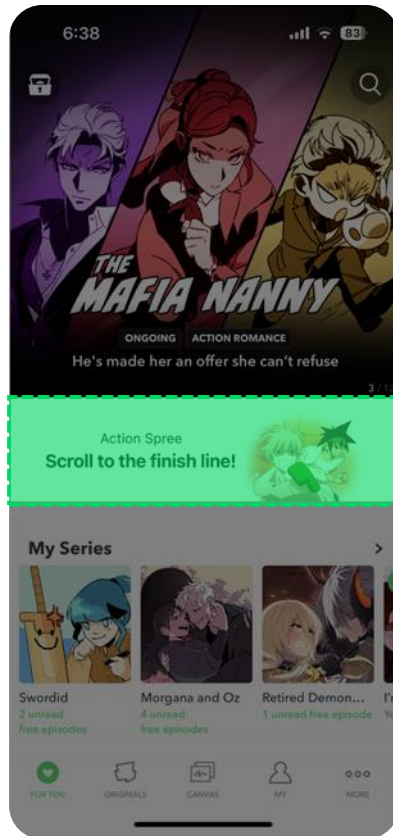

Length & Height (+ Margin)

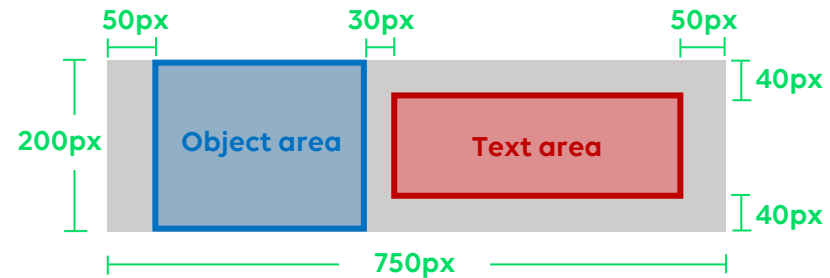

* For detailed guideline, refer to the sample mock-up provided through PSD.

Specifications

File type	File size limit	Length & Height
PNG	150KB	750 x 200

- * **Transparent Background image in PNG format only**
- * The object can be place either on the left-hand side or on the right-hand side
- * Use visible and readable fonts for copy line
- * Brand logo, colored texts are also allowed for Text area
- * **Call-to-Action button is not allowed to insert**

Premium Home AD _ Native Image

BAD CASE for Native Image (750x200)



Opaque background (affordance/video still cuts cannot be seen)



Object image area incompliant with the guide

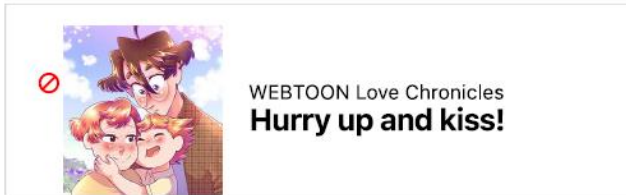

Object image with opaque baackground



Failure to use sample PSD for production of Text & Background type

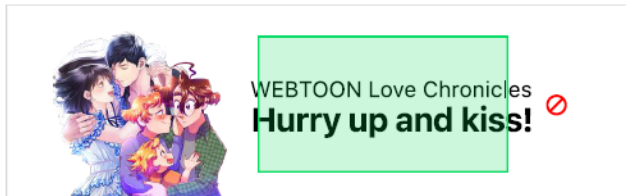

Text area incompliant with the guide (part of the text may be cropped)

Premium Home AD _ Image Banner

Placement

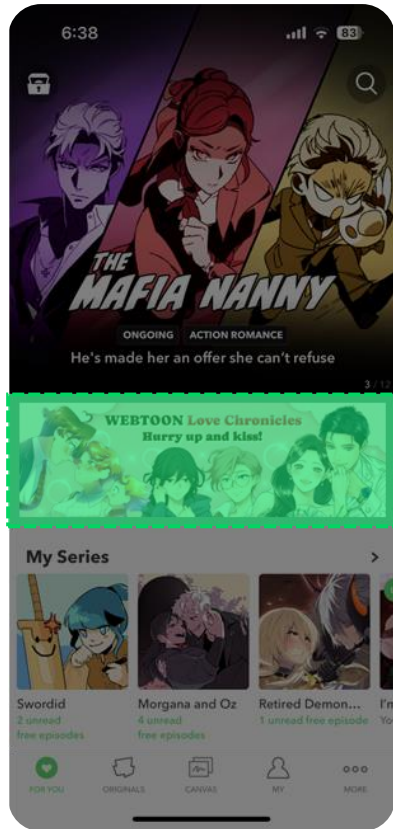

Length & Height



Specifications

File type	File size limit	Length & Height
JPG, PNG	150KB	640 x 200

* 1px border must be applied (Color : #000000, Transparency : 10%)

Premium Home AD _ Image Banner

Text Guides (Recommendation)



Min 20px height
Max 70px height

Text Placement

Observe the 10px margins on all sides

Font Type

Recommend to use highly readable fonts like Gothics, and 100% ratios for letter length

Text Color

Up to 3 colors are recommended including one basic color and two point-colors.
(Except for the advertiser logo)

Text Size

Text size should be applied between min 22px and max 70px height
The copy will use 2 or max 3 lines except for the logo

Caution

Cannot use top-notch expressions without reliable documents and certificates, when mentioning the competitors and their products

In-Viewer

Placement

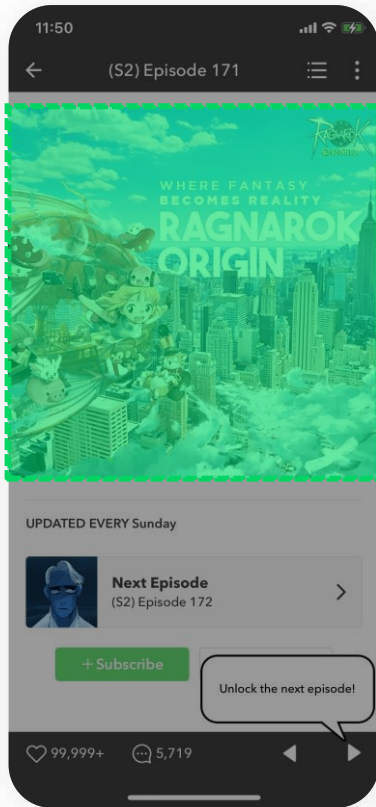

M.APP

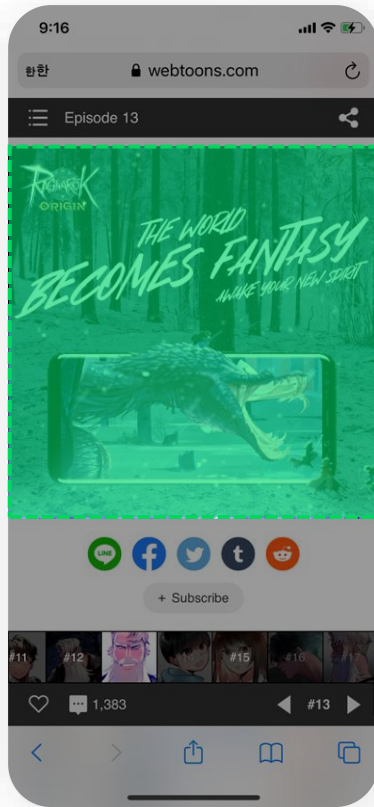

M.WEB

Length & Height

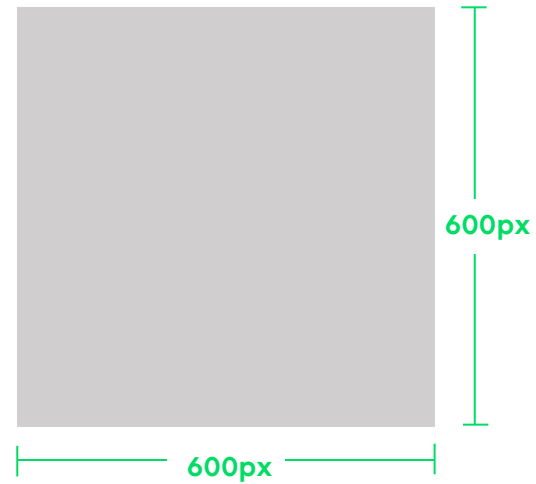

Specifications

File type	File size limit	Length & Height
JPG, PNG	150KB	600x600

* 1px border must be applied (Color : #000000, Transparency : 10%)

Series Home AD

Placement

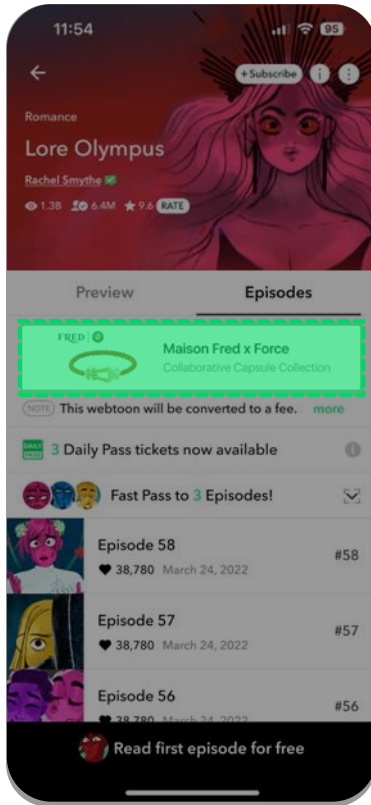

Length & Height

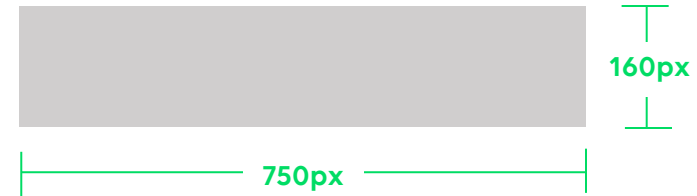

Specifications

File type	File size limit	Length & Height
PNG	150KB	750x160

- Text is placed within the designated area and the copy uses two basic lines
- Text height: Main copy: 30px (Bold) / Sub copy: 26px (Regular)

User Profile _ App only

Placement

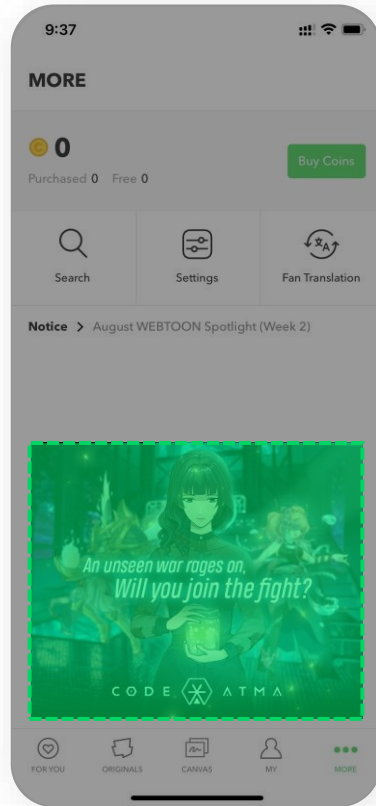

Length & Height

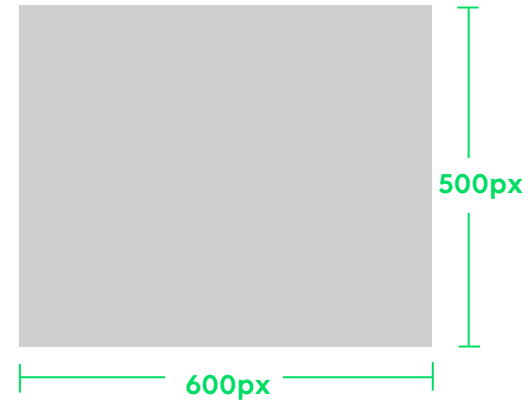

Specifications

File type	File size limit	Length & Height
JPG, PNG	150KB	600x500

* 1px border must be applied (Color : #000000, Transparency : 10%)

1:1 Video (In-Viewer)

Placement

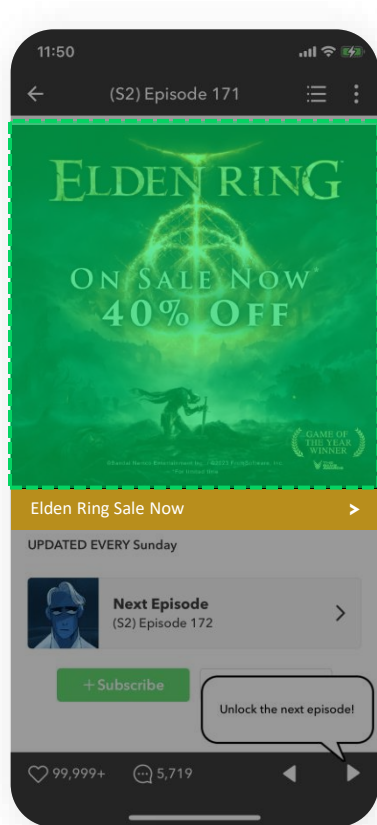

Length & Height

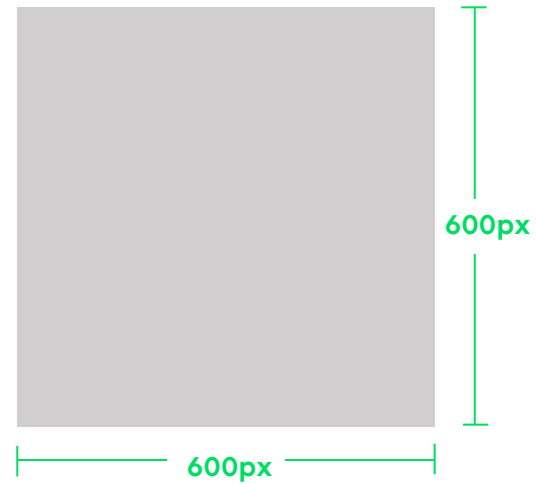

Specifications

	File type	File size limit	Length & Height
Still image	JPG, PNG	150KB	600x600
Video	MP4, AVI	30MB (~15sec)	1 : 1

1:1 Video (In-Viewer)

Placement

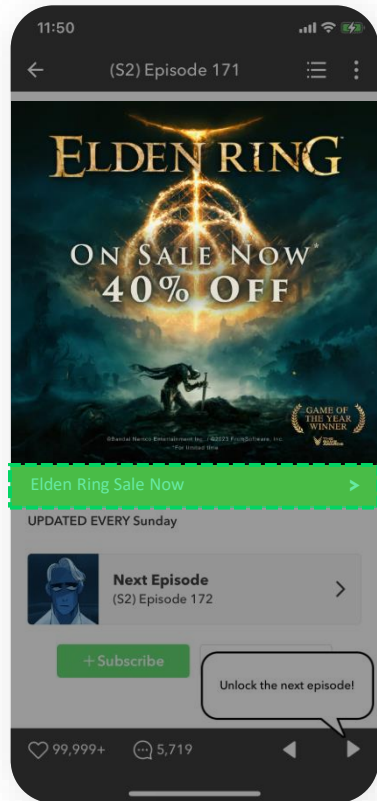

CTA button option

RED



ORANGE



YELLOW



BROWN

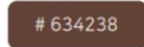

COCOA



GOLD



OLIVE



GREEN



BLUE GREEN



KHAKI

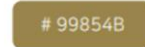

EVER GREEN



SEA GREEN



BLUE



SKY BLUE



DARK BLUE

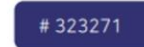

CYAN

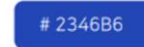

MINT



INDIGO



PURPLE



VIOLET



PINK



MAGENTA

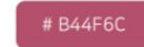

LAVENDER

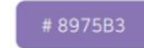

LILAC

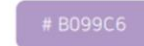

GRAY



BLUE GRAY



DARK GRAY

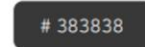

CHARCOAL GRAY



ROSE GRAY



SKY GRAY



Full Screen Video (non skip 30 sec)

Placement

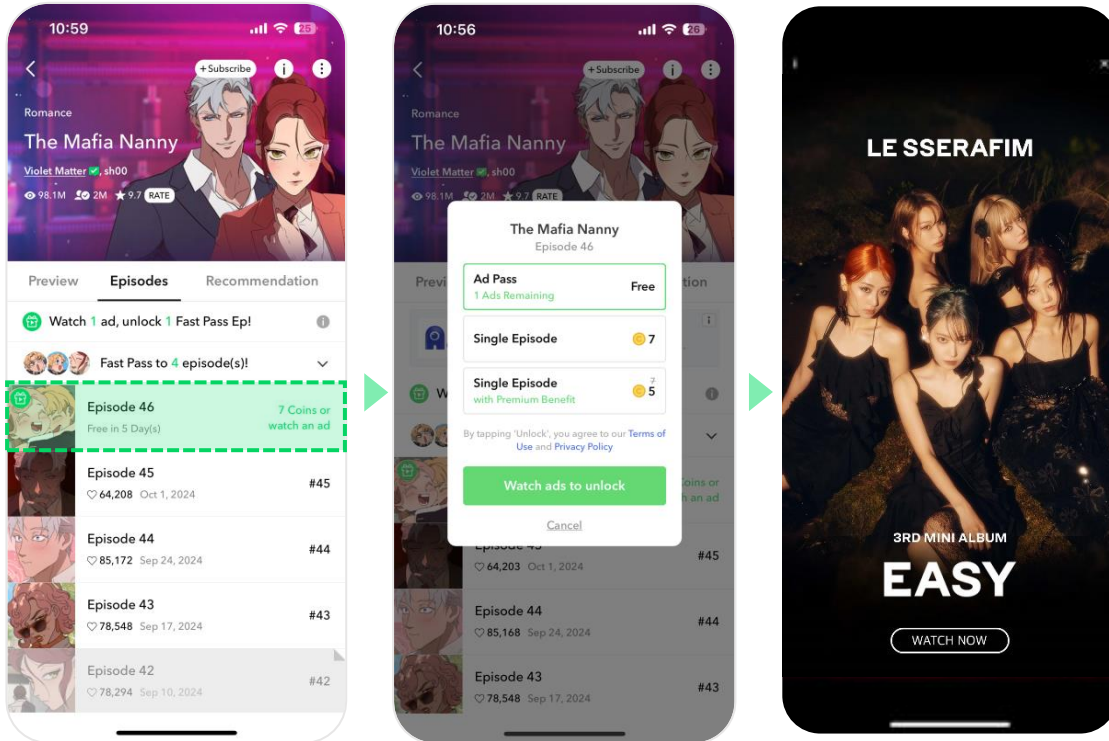

Length & Height

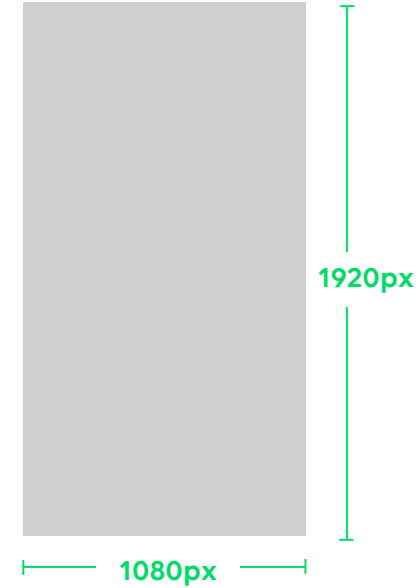

Specifications

	File type	File size limit	Length & Height
Video	MP4	50MB (~30sec)	1080 x 1920
End Card Image	JPG, PNG	5MB	1080 x 1920

Display Ads Desktop

- ✓ The asset can be placed on one or more of the below placements
- ✓ Various placements of Ads leaving a long-lasting impression of your brand

Leaderboard

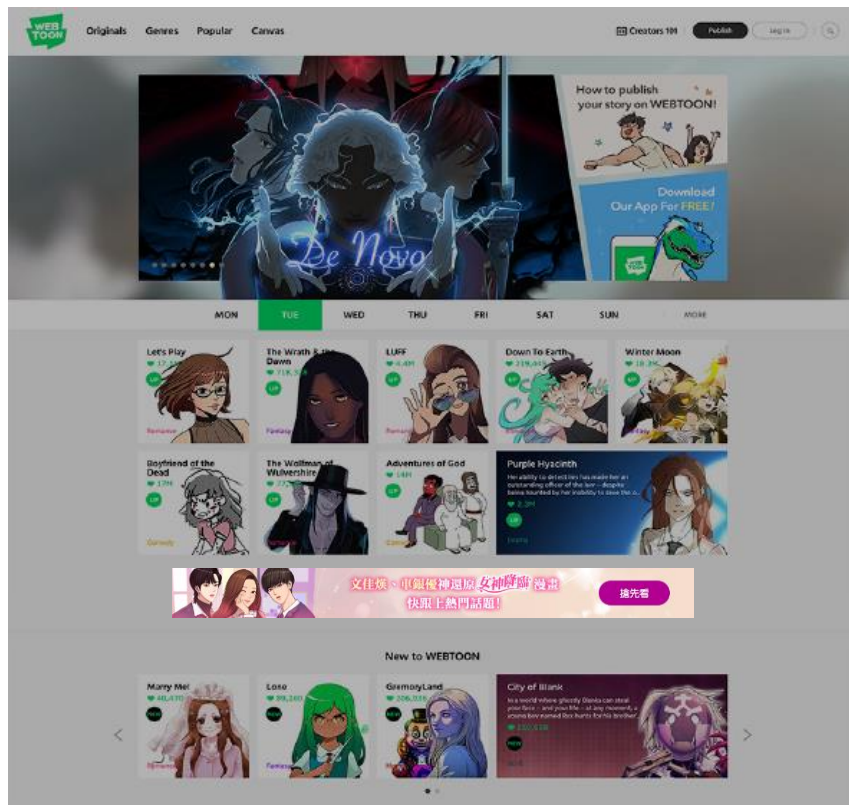

In-Viewer

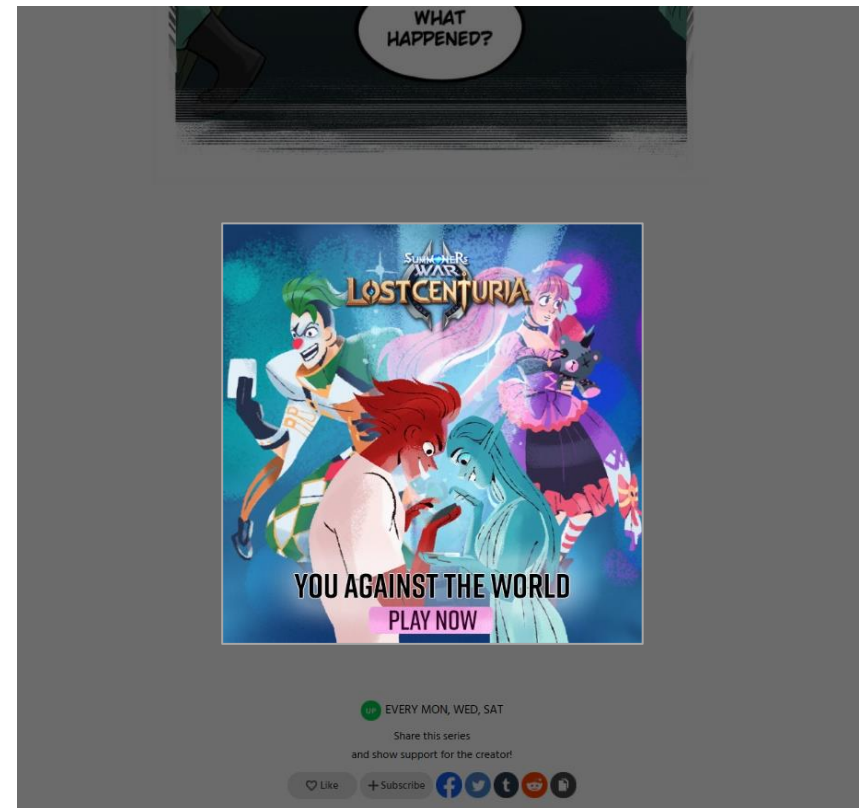

Main Leaderboard

Placement

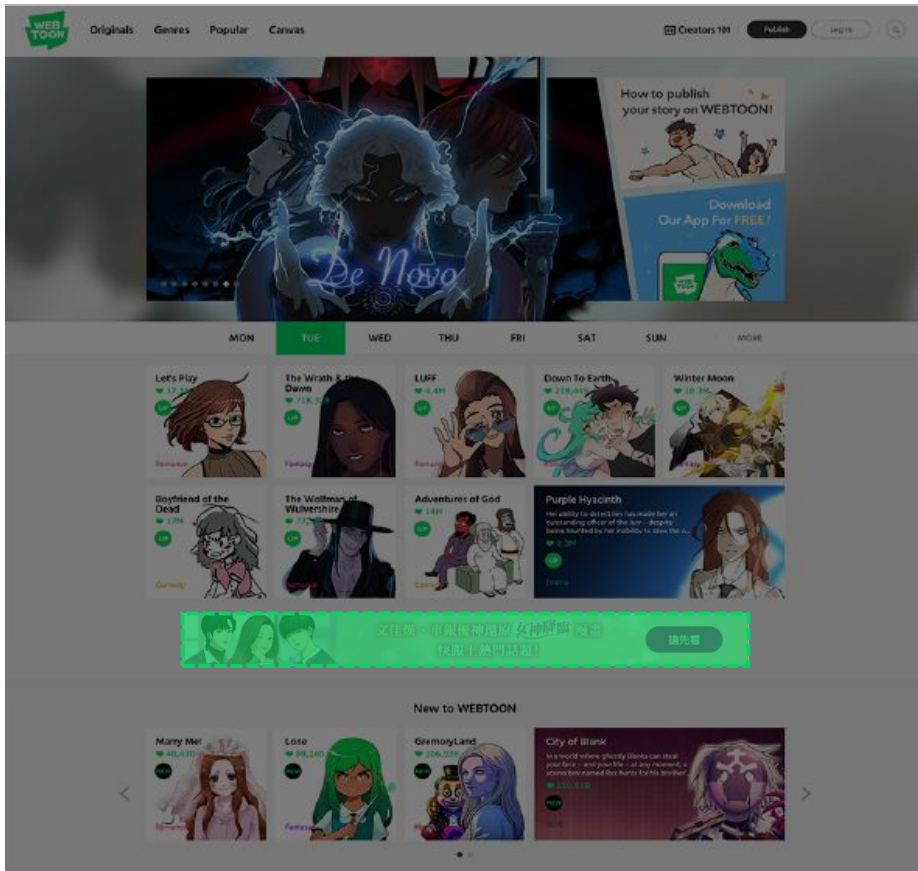

Length & Height

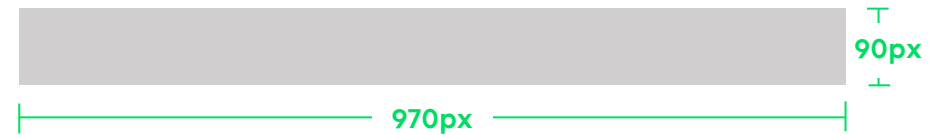

Specifications

File type	File size limit	Length & Height
JPG, PNG	150KB	970x90

* 1px border must be applied (Color : #000000, Transparency : 10%)

In-Viewer

Placement

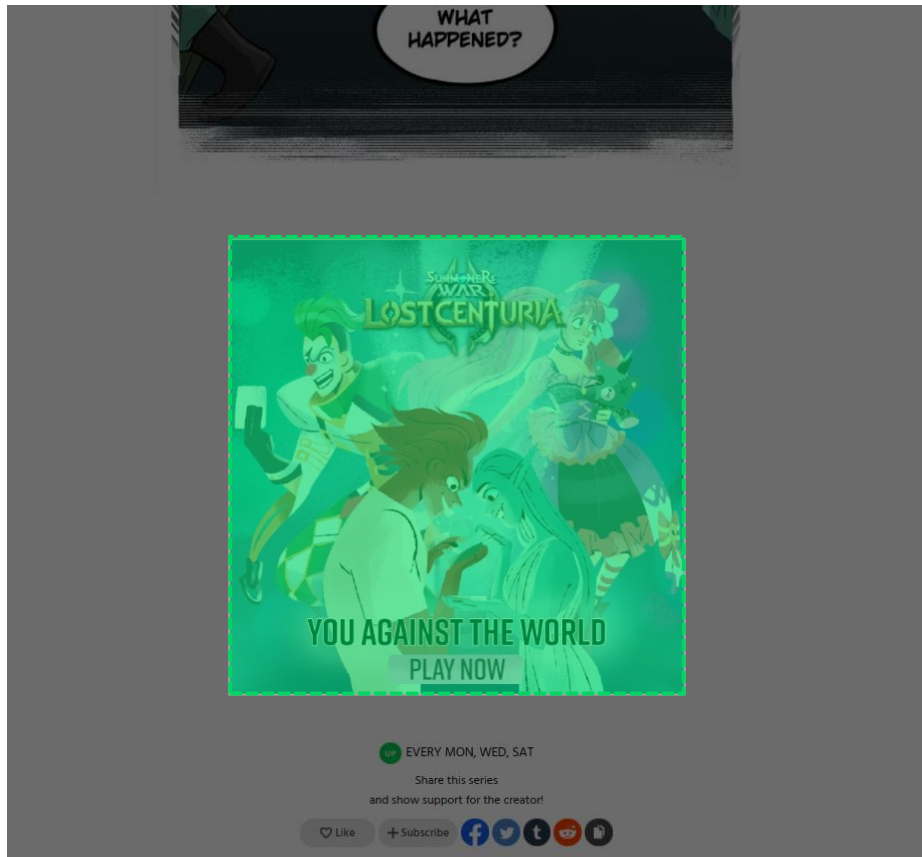

Length & Height

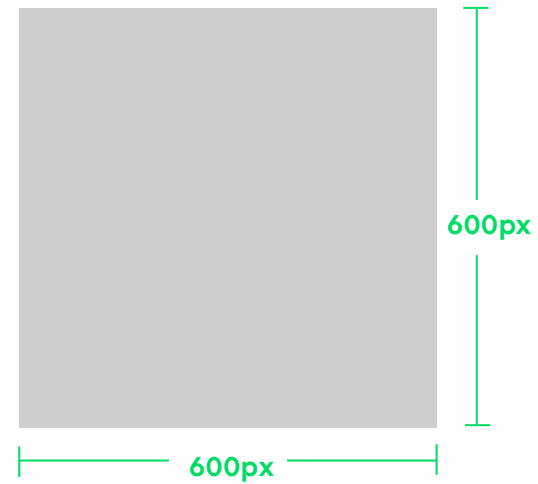

Specifications

File type	File size limit	Length & Height
JPG, PNG	150KB	600x600

* 1px border must be applied (Color : #000000, Transparency : 10%)

Mobile (App & Web)

* Pixels

Placement	File type	File size limit	Length & Height
Premium Home AD : Native Image	PNG	150KB	750 x 200
Premium Home AD : Banner Image	JPG, PNG	150KB	640 x 200
In-Viewer	JPG, PNG	150KB	Mobile App 600 x 600 Mobile Web 600 x 600
Series Home DA (App only)	PNG	150KB	750x160
User Profile (App only)	JPG, PNG	150KB	600 x 500

Desktop

* Pixels

Placement	File type	File size limit	Length & Height
Leaderboard	JPG, PNG	150KB	970x90
In-Viewer	Image JPG, PNG	Image 150KB	600 x 600

Premium Home Ad _ Interactive Video

Asset	16 : 9 video
File type	MP4, AVI, WMV, MPG, MPEG
File size	Max. 1GB (internally encoded)
Video length	Up to 60 seconds of playtime. but the recommended length is up to 30 seconds. * Please make sure not to exceed 60.00 sec
Size ratio	W1920px * H1080px

Asset	File type	File size limit	Length & Height
Premium image	PNG	150KB	750 x 230
Video still cut	JPG, PNG	150KB	640 x 360
Default Image	PNG	150KB	750 x 200

[PSD File](#)

- The video should be relevant to the ad message
- Sound must be included

1:1 Video (In-Viewer)

Ad type	1:1 Video
File type	MP4, 3GPP, MOV or AVI
File size	Max. 30 MB
Video length	The length can exceed 15 sec, but the recommended length is up to 15 seconds.
Size ratio	1:1

Full Screen Non Skip Video

Ad type	Rewarded Video
File type	MP4
File size	Max. 50 MB
Video length	The recommended length is up to 30 seconds. Videos that are up to 30 seconds are non-skippable. The length can exceed 30 sec, but users will be able to skip the video after 30 sec.
Size ratio	1080 x 1920

- Our ad server adjusts the video quality automatically if the file size is too large.
- Files that do not fit in the ratio will be automatically adjusted to 4:3 ratio.
- Expandable and Interstitial videos are prohibited.

Display Ads: Recommended



In-Viewer

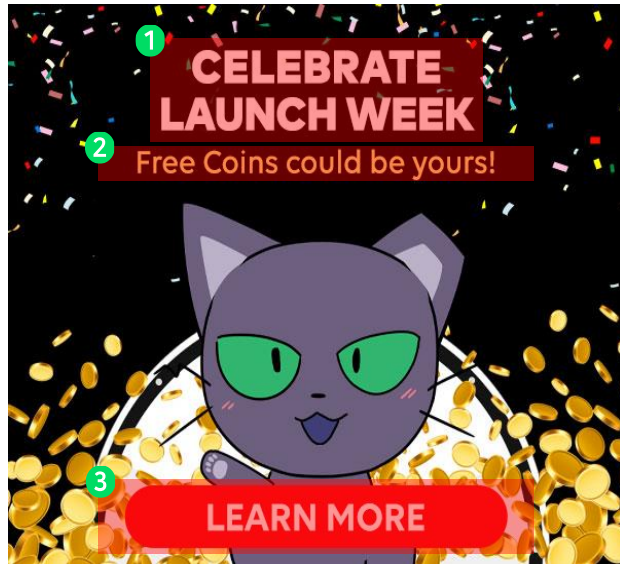

- 1 Headline copy or Brand logo
- 2 Sub-head
- 3 Call-to-Action Button

Caution

Cannot use top-notch expressions without reliable documents and certificates, when mentioning the competitors and their products

Main-mid & Leaderboard



- 1 Headline copy or Brand logo
- 2 Sub-head
- 3 (Optional) Call-to-Action Button

E.O.D